

軸用C形止め輪《STW-3~56》

適用する軸

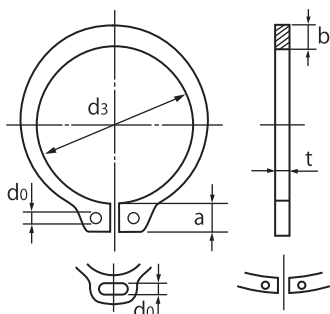

サイズNo.9以下 サイズNo.170以上

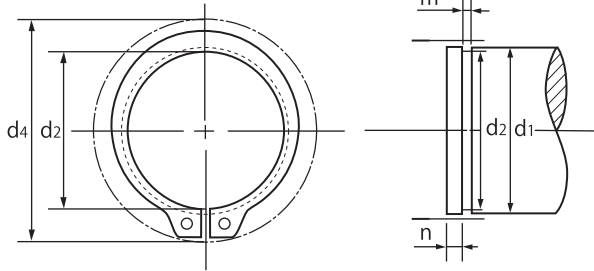

d4は止め輪をd1にはめる時の外周の最大径
(クリアランス外径)

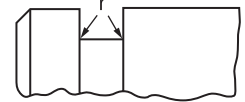

サイズNo.	溝底r(最大)
7未満	鋭角
7~10未満	0.08
10~26未満	0.13
26以上	0.25

単位:mm

サイズNo.	止 め 輪							適 用 す る 軸						
	d3		t		b	a	d0	d4 (参考)	d1	d2		m		参考n 最小
	基本寸法	公差	基本寸法	公差	約	約	最小			基本寸法	公差	基本寸法	公差	
STW-※ 3	2.7	+0.04	0.25	±0.025	0.5	1.7	0.7	7	3	2.85		0.35	+0.1 0	0.3
※ 4	3.7	-0.15	0.4	±0.03	0.9	2.2	0.8	9	4	3.8	0	0.5		0.3
※ 5	4.7		0.6	±0.04	1.1	2.4	0.8	10.5	5	4.8	-0.04	0.7		0.3
※ 6	5.6		0.7		1.3	2.8	1	12	6	5.7		0.8	0.5	
※ 7	6.5	+0.06	0.8	±0.05	1.4	3	1	14	7	6.7	0	0.9	0.5	
※ 8	7.4	-0.2	0.8		1.6	3	1	15	8	7.6	-0.06	0.9	0.6	
※ 9	8.4		1	±0.06	1.8	3.2	1	16	9	8.6		1.15	0.6	
※ 10	9.3	±0.15	1		1.8	3	1.2	17	10	9.6	-0.09	1.15	1.5	
※ 11	10.2		1	±0.05	2	3.1	1.2	18	11	10.5		1.15	1.5	
※ 12	11.1		1		2.1	3.2	1.5	19	12	11.5		1.15	1.5	
※ 13	12		1	±0.06	2.1	3.3	1.5	20	13	12.4		1.15	1.5	
※ 14	12.9		1		2.2	3.4	1.7	22	14	13.4	0	1.15	1.5	
※ 15	13.8	±0.18	1	±0.06	2.2	3.5	1.7	23	15	14.3	-0.11	1.15	1.5	
16	14.7		1		2.2	3.6	1.7	24	16	15.2		1.15	1.5	
17	15.7		1	±0.07	2.2	3.7	1.7	25	17	16.2		1.15	1.5	
18	16.5		1.2		2.6	3.8	1.7	26	18	17		1.35	1.5	
19	17.5		1.2	±0.06	2.7	3.8	2	27	19	18		1.35	1.5	
20	18.5		1.2		2.7	3.9	2	28	20	19		1.35	1.5	
21	19.5		1.2	±0.06	2.7	4	2	30	21	20		1.35	1.5	
22	20.5		1.2		2.7	4.1	2	31	22	21		1.35	1.5	
※ 23	21.4		1.2	±0.06	2.9	4.5	2	32.5	23	22		1.35	1.5	
24	22.2		1.2		3.1	4.2	2	33	24	22.9	0	1.35	1.7	
25	23.2	±0.2	1.2	±0.06	3.1	4.3	2	34	25	23.9	-0.21	1.35	1.7	
26	24.2		1.2		3.1	4.4	2	35	26	24.9		1.35	+0.14 0	
※ 27	25		1.2	±0.07	3.3	4.5	2	36	27	25.8		1.35	1.8	
28	25.9		1.5		3.1	4.6	2	38	28	26.6		1.65	2.1	
29	26.9		1.5	±0.07	3.5	4.7	2	39	29	27.6		1.65	2.1	
30	27.9		1.5		3.5	4.8	2	40	30	28.6		1.65	2.1	
32	29.6		1.5	±0.07	3.5	5	2.5	43	32	30.3		1.65	2.6	
34	31.5		1.5		4	5.3	2.5	45	34	32.3		1.65	2.6	
35	32.2	±0.25	1.5	±0.07	4	5.4	2.5	46	35	33		1.65	3	
○ 36	33.2		1.75		4	5.4	2.5	47	36	34		1.9	3	
○ 38	35.2		1.75	±0.07	4.5	5.6	2.5	50	38	36		1.9	3	
○ 40	37		1.75		4.5	5.8	2.5	53	40	38	0	1.9	3	
○ 42	38.5		1.75	±0.07	4.5	6.2	2.5	55	42	39.5	-0.25	1.9	3.8	
○ 45	41.5		1.75		4.8	6.3	2.5	58	45	42.5		1.9	3.8	
※ 47	43.4	±0.4	1.75	±0.07	5	6.6	2.5	61	47	44.5		1.9	3.8	
○ 48	44.5		1.75		4.8	6.5	2.5	62	48	45.5		1.9	3.8	
50	45.8		2	±0.07	5	6.7	2.5	64	50	47		2.2	4.5	
52	47.8		2		5	6.8	2.5	66	52	49		2.2	4.5	
55	50.8	±0.45	2	±0.07	5	7	2.5	70	55	52	0	2.2	4.5	
56	51.8		2		5	7	2.5	71	56	53	-0.3	2.2	4.5	

単位:mm

サイズNo.	止 め 輪							d ₄ (参考)	適 用 す る 軸					
	d ₃		t		b	a	d ₀		d ₁	d ₂		m		参考 n
	基本寸法	公差	基本寸法	公差	約	約	最小			基本寸法	公差	基本寸法	公差	最小
STW-58	53.8		2		5.5	7.1	2.5	73	58	55		2.2		4.5
60	55.8		2	±0.07	5.5	7.2	2.5	75	60	57		2.2		4.5
62	57.8		2		5.5	7.2	2.5	77	62	59		2.2		4.5
63	58.8		2		5.5	7.3	2.5	78	63	60		2.2		4.5
65	60.8		2.5		6.4	7.4	2.5	81	65	62		2.7		4.5
68	63.5	±0.45	2.5		6.4	7.8	2.5	84	68	65	0	2.7	+0.14	4.5
70	65.5		2.5		6.4	7.8	2.5	86	70	67	-0.3	2.7	0	4.5
72	67.5		2.5	±0.08	7	7.9	2.5	88	72	69		2.7		4.5
75	70.5		2.5		7	7.9	2.5	92	75	72		2.7		4.5
78	73.5		2.5		7.4	8.1	2.5	95	78	75		2.7		4.5
80	74.5		2.5		7.4	8.2	2.5	97	80	76.5		2.7		5.3
82	76.5		2.5		7.4	8.3	3	99	82	78.5		2.7		5.3
85	79.5		3		8	8.4	3	103	85	81.5		3.2		5.3
88	82.5		3		8	8.6	3	106	88	84.5	0	3.2		5.3
90	84.5		3		8	8.7	3	108	90	86.5	-0.35	3.2		5.3
95	89.5		3		8.6	9.1	3	114	95	91.5		3.2		5.3
100	94.5		3		9	9.5	3	119	100	96.5		3.2	+0.18	5.3
105	98	±0.55	4		9.5	9.8	3	125	105	101		4.2	0	6
110	103		4		9.5	10	3	131	110	106	0	4.2		6
115	108		4		9.5	10.5	3	137	115	111	-0.54	4.2		6
120	113		4		10.3	10.9	3	143	120	116		4.2		6
125	118		4		10.3	11.3	3.5	148	125	121		4.2		6
130	123		4		11	11.5	3.5	154	130	126		4.2		6
135	128		4		11	11.5	3.5	159	135	131		4.2		6
140	133		4	±0.09	11	11.8	3.5	164	140	136		4.2		6
145	138		4		11.6	11.8	3.5	170	145	141		4.2		6
150	142	+0.63	4		11.6	12.3	3.5	175	150	145	0	4.2		7.5
155	146	-1.26	4		12.2	12.7	3.5	181	155	150	-0.63	4.2		7.5
160	151		4		12.2	12.9	3.5	186	160	155		4.2	+0.2	7.5
165	155.5		4		12.9	13.1	3.5	192	165	160		4.2	0	7.5
170	160.5		4		12.9	—	4	197	170	165		4.2		7.5
175	165.5		4		12.9	—	4	202	175	170		4.2		7.5
180	170.5		4		13.5	—	4	208	180	175		4.2		7.5
185	175.5		4		13.5	—	4	213	185	180		4.2		7.5
190	180.5		4		14	—	4	219	190	185		4.2		7.5
195	185.5		4		14	—	4	224	195	190		4.2		7.5
200	190.5	+0.72	4		14	—	4	229	200	195		4.2		7.5
210	198	-1.44	5		14	—	4	239	210	204	0	5.2		9
220	208		5		14	—	4	249	220	214	-0.72	5.2		9
230	218		5		14	—	4	259	230	224		5.2		9
240	228		5		14	—	4	269	240	234		5.2		9
250	238		5	±0.15	14	—	4	279	250	244		5.2	+0.25	9
260	245		5		16	—	4	293	260	252		5.2	0	12
270	255		5		16	—	4	303	270	262	0	5.2		12
280	265	+0.81	5		16	—	4	313	280	272	-0.81	5.2		12
290	275	-1.62	5		16	—	4	323	290	282		5.2		12
300	285		5		16	—	4	333	300	292		5.2		12

材質:ばね用鋼 硬さ:44~53HRC 表面処理:ACP(磷酸塩被膜)

注意点

- ※印及びSTW-130以上はオチアイ規格です。また、○印は旧JIS規格になります。
- 市場性の無い製品は在庫が無い場合があります。ご採用の際は事前にご確認ください。